



SURGICALLY CLEAN AIR™

AIR PURIFIER
JADE™ (SCA5000C)

Operation Manual



Intertek
5011884

CONFORMS TO UL STD. 867
CERTIFIED TO CSA STD. C22.2 No. 187

TABLE OF CONTENTS

HOW IT WORKS	4
SAFETY PRECAUTIONS	5
FEATURES AND SPECIFICATIONS	6
PART NAME	7
INSTALLATION	8-9
OPERATING FEATURES	10-11
CARE AND MAINTENANCE	12-13
TROUBLESHOOTING	14

HOW IT WORKS

When the DC fan motor is running, the indoor air will be drawn through the bottom of the unit. The air will then pass through the HEPA-Rx Filter, the Activated Carbon Filter and the UV-C+ chamber. The purified air is then released through the outlet on the top of the unit. The Revitalizing Negative Ion Generators near the air outlet releases revitalizing negative ions into the air to refresh the air.

The air is purified in multiple stages:

1. PRE-FILTER STAGE

The pre-filter stage catches the largest particles as room air is drawn through the intake chamber.

2. PROPRIETARY HEPA-Rx FILTER

The HEPA-Rx filter captures >99.9% of the ultrafine particulates down to 0.0025 microns in size.

3. ACTIVATED CARBON FILTER

The activated carbon filter adsorbs VOCs (Volatile Organic Compounds)- noxious odours, chemicals and gases.

4. UV-C+ LAMP

The UV-C+ Lamp is implemented to eliminate (reduce the concentration of) airborne pathogens.

5. REVITALIZING NEGATIVE ION CHAMBER

Before the pure, clean air is circulated back into the room, the air is revitalized with negative ions. Studies have shown that Negative ions increase the flow of oxygen to the brain; resulting in higher alertness, decreased drowsiness and more mental energy.

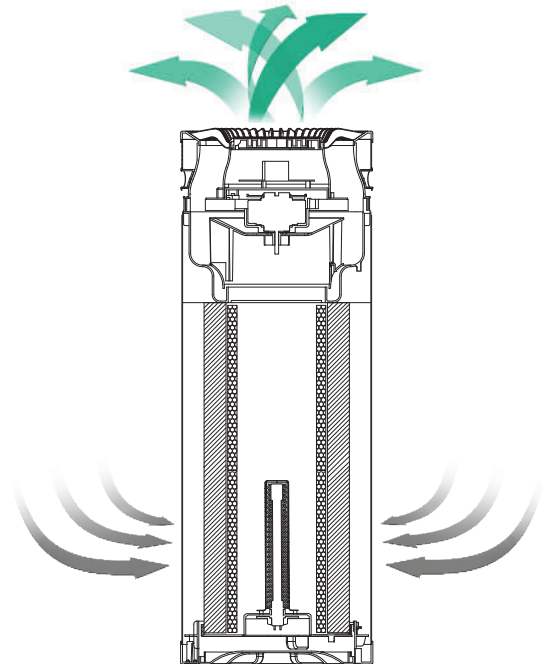

SAFETY PRECAUTIONS

Be sure to follow all precautions below:

Running Environment Cautions

- Use only a 120-volt outlet with grounding wire receptacle.
- Do not put it in rooms with high heat, damp or wet places.
- Best working condition is 10-40°C.
- Level the unit well, never use unit when it is tilted or laying down.
- To reduce the risk of electric shock, this equipment has a grounding type plug that has a third (grounding) pin. This plug will only fit into a grounding type power outlet. If the plug does not fit into the outlet, contact qualified personnel to install the proper outlet. Do not alter the plug in any way.

Unit Operation

- Do not insert fingers or foreign objects into the intake or air outlet.
- Keep hair, loose clothing, fingers and all parts of body away from openings and moving parts.
- Do not block the air intake and air outlet.
- Do not use the air purifier if the power cord or plug is damaged or the connection to the wall outlet is loose.
- When removing the power plug, always hold the plug and never pull by the cord.
- Do not use the unit near or on hot objects, such as range or where it may be exposed to steam.
- Stop the unit and unplug the power when moving or maintenance. Always hold the handles on the side of the unit when moving it.
- To avoid causing fire and/or shock do not attempt to disassemble the unit - only certified technicians should do this.
- Never insert small things into the air intake/outlet.



WARNING

The internal UV-C+ lamp contains a small amount of mercury which is contained inside the bulb unless broken. Mercury and mercury compounds are known to the State of California to cause birth defects or other reproductive harm. For more information, go to www.p65warnings.ca.gov

FEATURES AND SPECIFICATIONS

The unit has a HEPA-Rx Filter (removes particles), Activated Carbon Filter (adsorbs gases), UV-C+ lamp (eliminates airborne pathogens) and two Revitalizing Negative Ion generators.

The JADE™ can be operated completely with the wave of your hand, making it suitable to avoid cross contamination.

The JADE™ is also equipped with a safety interlock switch that will turn the power off if the bottom plate is opened.

Model No.	JADE™ (SCA5000C)
Power Requirement	120V, 60Hz
Rated Power	78W, 1.1A
Negative Ion	2 x 3x10 ⁶ /cm ³
UV Lamp	10W
Dimensions	Φ30.5cm x 85cm (Φ12 inches x 33.5 inches)
Weight	13.9kg (30.6 pounds)

PART NAME

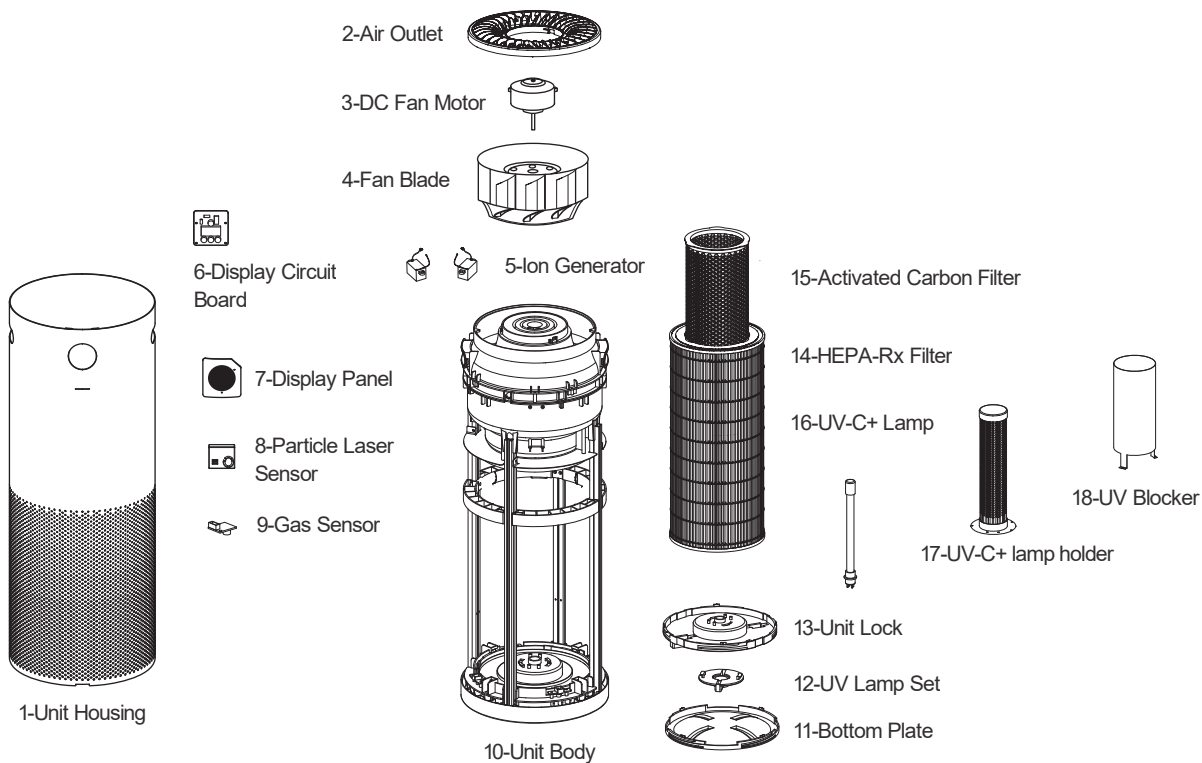

INSTALLATION

Prior to using unit for the first time, you must remove the plastic bag from the HEPA-Rx Filter inside the unit.

1. Turn unit upside down - put towel or any soft pad on the ground to avoid damage to the unit when you turn it upside down.
2. Open unit from the bottom - turn counterclockwise to open bottom as pictured below. (Pic.1)
3. After the plastic bottom is removed, pull out the power cord of the UV-C+ lamp, open the unit lock (Pic.2) and take out the HEPA-Rx Filter and the Activated Carbon Filter to remove the plastic cover.

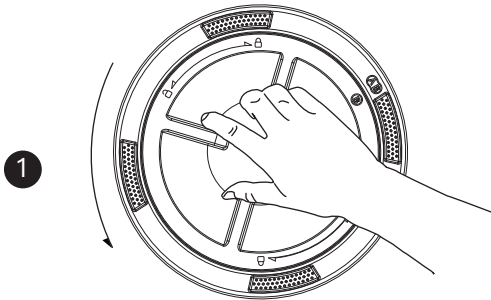

Turn counterclockwise
to open bottom

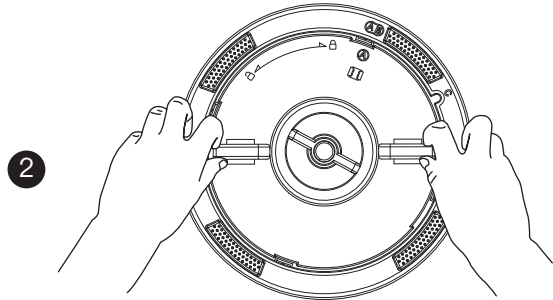

Open the unit lock and
take out the filters

4. Once plastic bag is removed, put unit back together.

5. Put the HEPA-Rx Filter and Activated Carbon Filter back into unit. Align letter A with the letter A, turn the unit lock clockwise until the letter A is aligned with the letter C. (See pic.1)

6. Re-connect the UV power cord, align letter B with the letter B and turn the unit bottom clockwise until the letter B is aligned with the letter C. (See pic.2)

ATTENTION:

For optimal purification, make sure there is a gap between air inlet and anything that may block the airflow nearby.

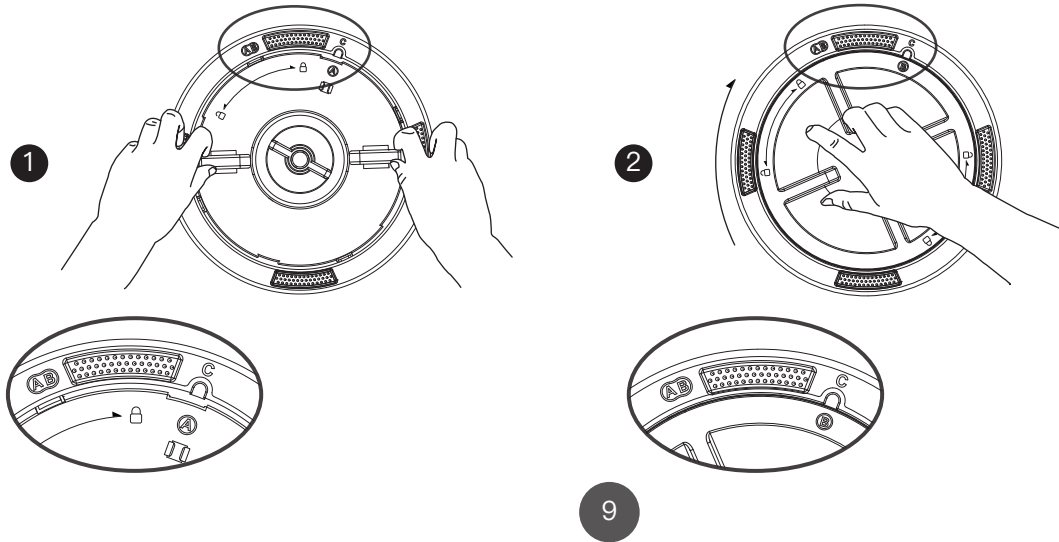

OPERATION FEATURES

Plug the power cord in and you will hear a “Beep”. The small, inner circle will turn green - this indicates the air purifier is in **standby mode**. Use your hand to wave over the sensor, this waving motion turns the unit on & off, and can also adjust the fan speed.

(Wave 1) Wave your hand the 1st time and the green circle will turn white - low speed.

(Wave 2) Wave a 2nd time, the second circle will light up - medium speed.

(Wave 3) Wave a 3rd time, the third circle will light up - high speed.

(Wave 4) Wave a 4th time, all the circles light up white - turbo speed.

(Wave 5) Wave a 5th time, the first circle (green light) and the second circle (white light) will light up together. This is **Auto Mode** - the unit will operate on low speed and will adjust speeds accordingly base on what pollution the sensors pick un in the air.

(Wave 6) Wave 6th time, the unit goes back to **standby Mode** and the inner circle turns back to green.

Hover & hold your hand over the sensor for 2 seconds and this will lock the unit at the desired speed. This will prevent accidental or unwanted speed changes. To unlock this feature, hover & hold your hand over the sensor again for 2 seconds.

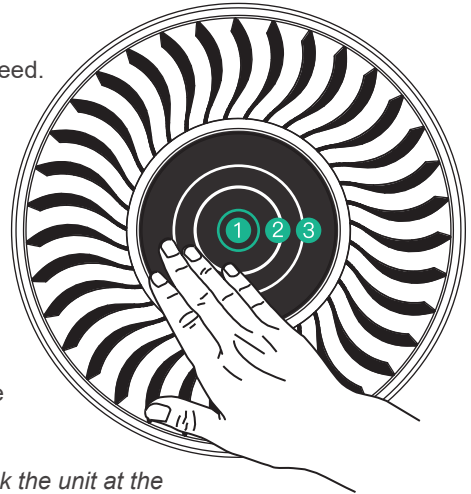

OPERATION FEATURES

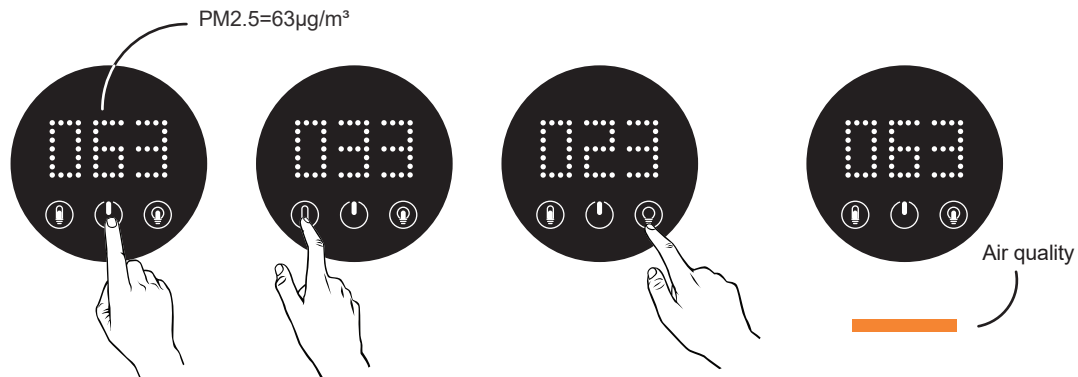

1. Touch POWER button

2. Touch UV button

3. Touch LIGHT button

4. Different colors indicate the air quality

1. POWER Button

Touch the POWER button to start the unit, the unit will run at low speed and the screen displays PM2.5 concentration ($\mu\text{g}/\text{m}^3$) on the screen, re-touch it to stop.

2. UV LAMP Button

When the UV LAMP button is touched, it will turn off the UV lamp, touching again will turn on the UV lights. The indicator light will light up when the UV light is on.

3. LIGHT Button

When the LIGHT button is touched, all the light indicators will turn off. Touching button again or wave your hand over the top and the indicator lights will turn on again.

4. The different colors indicate the air quality: Green=Good Orange=Moderate Red=Poor



CARE AND MAINTENANCE

To maintain optimum performance of this air purifier, the HEPA-Rx Filter, the Activated Carbon Filter and the UVC+ lamp need to be replaced when the indicator lights are flashing. If in an atmosphere with heavy dust, particulate or pet dander, you may need to periodically vacuum the filters for optimal performance.

This product complies with the maximum allowable concentration of ozone of 0.050 parts per million by volume (ppmv) in a 24-hour period. The Health Canada Guideline 2010 recommends that the maximum exposure limit, based on an averaging time of 8 hours, is 0.020 ppmv or less when tested in a sealed, controlled room approximately 30 m³.

Ce produit est conforme avec la concentration maximale permise d'ozone de 0,050 parties par million par volume (ppmv) pendant une période de 24 heures. La Ligne directrice (2010) de Santé Canada recommande un niveau maximal d'exposition, basé sur un moyen de 8 heures, soit 0,020 ppmv ou moins dans une chambre de teste étanchée et contrôlée de 30 m³.

Main Unit

Wipe with a dry, soft cloth for stubborn stains or dirt. Do not use **volatile fluids, benzene, paint thinner or polishing powder** as this may damage the surface.

Do not use detergents as detergent ingredients may also damage the unit. Keep the unit away from water.

Warning

1. Turn off and unplug the power cord before cleaning the body, air outlet or opening the bottom to avoid electric shock.
2. Turn off and unplug the power cord before replacement of the HEPA-Rx Filter, Activated Carbon Filter and the UV-C+ lamp or unit maintenance. If the power cord is damaged, it must be replaced by the service center or a similarly qualified person.

CARE AND MAINTENANCE – continued

When the “POWER” indicator light flashes, the HEPA-Rx filter needs to be replaced.

When the “LIGHT” indicator light flashes, the Activated Carbon Filter needs to be replaced.

When the “UV” indicator light flashes, it is time to replace the UV-C+ lamp.

Note: Dispose of filters according to local regulations based on location of use (e.g. medical waste if used in dental operatories)



POWER indicator
light flashes

Replacing the HEPA-Rx filter

When the “POWER” indicator light flashes, the HEPA-Rx filter needs to be replaced.

1. Stop the operation and unplug the unit.
2. Take out the used HEPA-Rx filter and replace with a new one (See page 8 & 9).
3. Hold the POWER button 3 seconds to reset the indicator light.

Replacing the Activated Carbon Filter

When the “LIGHT” indicator light flashes, the Activated Carbon Filter needs to be replaced.

1. Stop the operation and unplug the unit.
2. Take out the used Activated Carbon Filter and replace with a new one (See page 8 & 9).
3. Hold the LIGHT button 3 seconds to reset the indicator light.

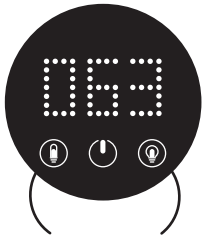

UV indicator
light flashes LIGHT indicator
light flashes

Replacing the UV-C+ lamp

When the UV indicator light flashes, it is time to replace the UV-C+ lamp.

1. Stop the operation and unplug the unit.
2. Open the bottom, disconnect the power cord from UV-C+ lamp, remove screw and then twist to open the UV Lamp Set to take out the used UV-C+ lamp.
3. Replace with a new one and put new UV-C+ lamp back in the unit, close the UV Lamp Set, re-connect the power cord and put the bottom back on (See page 8 & 9).
4. Hold the UV button 3 seconds to reset the indicator light.

TROUBLESHOOTING

Service problems that appear to be major can often be solved easily. You can be your own troubleshooter by reviewing the following guide. All other servicing should be done by a SCA authorized service center.

Failure phenomenon	Checking	Method
The unit does not operate.	Power plug disconnected?	Make sure plug is fully inserted.
	Bottom plate or interlock switch failure?	The unit does not operate when the bottom panel is detached. Install properly. Check interlock switch.
	Power failure?	Check other electrical appliances.
When functions do not work properly.	There is too much dust on the HEPA-Rx Filter or the Activated Carbon Filter?	Replace the HEPA-Rx Filter or the Activated Carbon Filter.

UV-C+ lamps should only be purchased from Surgically Clean Air or an authorized dealer at Surgically Clean Air. This will ensure that you are receiving UV lamps that do not produce ozone. Many after-market sellers are selling ozone-generating UV lamps.



1A - 6300 Viscount Road
Mississauga, Ontario
Canada, L4V 1H3
Tel: 1-877-440-7770
www.surgicallycleanair.com
info@surgicallycleanair.com