

SURGICALLY CLEAN AIR™

AtomikAir (SCA9000)
SCA9000C240V

OPERATION MANUAL

Read the manual thoroughly before
operation and retain for future reference.

REV SCA9000-3

TABLE OF CONTENTS

SAFETY PRECAUTIONS -----	3
FEATURES-----	6
SPECIFICATIONS-----	7
PART IDENTIFICATION-----	10
INSTALLATION -----	11
OPERATION-----	15
CARE & MAINTENANCE-----	17
TROUBLESHOOTING -----	22

SAFETY PRECAUTIONS



Indicates an imminently hazardous situation which, if not avoided, will result in death or serious injury. Compliance with the measures is mandatory.



Danger from electric current or high voltage!



Important information.



WARNING – TO REDUCE THE RISK OF FIRE, ELECTRIC SHOCK, OR INJURY TO PERSONS OBSERVE THE FOLLOWING:

AtomikAir products are produced in accordance with the latest technical standards ensuring that the final product is of a high quality and durability. Nevertheless, these products can be dangerous if they are not used and installed correctly, according to the instructions.

All equipment installation, electrical connections, service, and maintenance work must be performed by trained and qualified personnel in accordance with all applicable codes and standards.

Do not make any additions, modifications, or repairs to the equipment without approval from Surgically Clean Air or an authorized distributor. Do not attempt to disassemble the unit.

Always follow all local regulations and codes.

SAFETY PRECAUTIONS



RUNNING ENVIRONMENT CAUTIONS

- Equipment is for indoor use only, do NOT use outdoors.
- Do NOT use in explosive atmosphere or with combustible or flammable gases, dust, and substances.
- Do NOT locate equipment in areas of high heat, excessively damp or wet places, such as walk-in ovens, shower rooms, or next to direct hot steam/exhaust. Condensate formation must be avoided.
- Equipment is supplied with a special 240V locking plug. This plug shall only be connected to a compatible, properly grounded outlet with correct voltage that is installed by qualified personnel in accordance with all applicable codes and standards. To reduce the risk of electric shock, this equipment has a grounding type plug. Do NOT alter the plug in any way.
- An electrical disconnect switch is supplied on the side of the equipment for emergency shut-off. Always ensure free and clear access to the switch.
- CAUTION HEAVY MACHINERY. Equipment is provided with casters and should be located on flat level surfaces. Caster locks must be engaged on all feet prior to operation and maintenance.
- Do NOT attempt to move the unit without unplugging (turn and pull locking plug) and unlocking casters. Casters should rotate freely when moving. Do NOT impact or shock load casters, do NOT ram or force over bumps, stairs, large debris, etc.
- Do NOT run the power cord under carpeting. Do not cover the cord with throw rugs, runners, or similar coverings. Do NOT run cord under furniture or appliances. Arrange cord away from traffic area and where it will not be tripped over.
- Equipment has top vented air outlet with open mesh, do NOT store or install equipment under falling debris.



This equipment provides air filtration with recirculation. Dust and particulate are collected on the exterior exposed filter faces of the unit. It is the responsibility of the owner to determine and follow safe practices for the appropriate collection and disposal of hazardous substances that does not result in harmful exposure to personnel.

SAFETY PRECAUTIONS



UNIT OPERATION CAUTIONS

- Do NOT operate equipment without all guards, access panels, and covers installed and securely fastened.
- Do NOT operate equipment without all casters in locked positions.
- Do NOT operate the equipment if the power cord or plug is damaged or the connection to the outlet is loose.
- Do NOT insert fingers or foreign objects through any openings in the equipment.
- Keep hair, loose clothing, fingers, and all parts of body away from openings and moving parts.
- Do NOT block the air intake and air outlet. Never insert anything into the air intake/outlet.
- Do NOT operate equipment in environments below -20° C and above 60° C.
- Maximum installation height is 2000m above sea level.

FEATURES

INDUSTRIAL AIR PURIFIER AND DE-STRATIFICATION SYSTEM

HIGH VOLUME AIR OUTPUT WITH VARIABLE SPEED SETTINGS

- Discharges clean air upward, circulating up to 11000 CFM
- Destratification of air (equalizes the temperature between floor and ceiling)
- Creates convection patterns for warm air recirculation
- Adjustable fan speed, can operate continuously at variable speeds, accommodating different space needs

HIGH FILTRATION CAPACITY

- Five large filters per machine, effectively cleans and purifies air at high volume by removing particulates

EASY, LOW-COST MAINTENANCE

- Semi-permanent filters can be easily removed, washed, and reused

GERMAN TECHNOLOGY FAN AND MOTOR

- Reliable fast start-up EC fan
- Rated for continuous RPM, partial to full load operation, and long-life duty
- Energy Saving Rated, ErP2015, Ins Class F
- CSA, and UL Recognized. CE Compliant.

BUILT FOR INDUSTRIAL ENVIRONMENT

- 14-gauge steel housing with baked on powder-coat finish (durable with no off-gassing)

PORTABILITY

- Easy roll, lockable, heavy-duty casters allow for easy positioning and maneuvering

MODBUS COMMUNICATION RTU SUPPORT

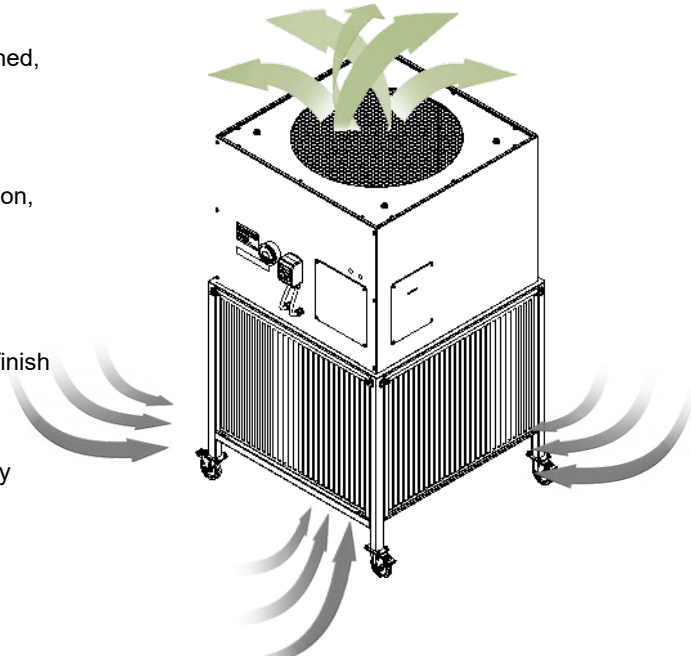

SPECIFICATIONS

GENERAL SPECIFICATIONS

MODEL NUMBER	SCA9000C240V
	3~200-240VAC, 5.4A, 50/60 Hz
DIMENSIONS (LxWxD)	53 x 50 x 86 in
WEIGHT	655 lbs (Without Filters) 720 lbs (Total)
CONSTRUCTION	14-gauge steel housing, Easy roll lockable casters (heavy duty), Baked on powder coat finish (durable with no off-gassing)
MAXIMUM AIRFLOW	11000 CFM
MAXIMUM SOUND LEVEL	70 dBA
FAN SPECIFICATION	
TYPE	Axial fan, vertical flow, fast start EC
RECEOGNITIONS	Class IE4, EN60034-30 Ins Class F, ERP 2015 CSA, UL Recognized EMV-Directive 2014/30/EU LVD-Directive 2014/35/EU ErP-Directive 2009/125/EC
MOTOR PROTECTION	Integrated active temp. management with electronic overload

SPECIFICATIONS

NAMEPLATE INFORMATION

1	Model Number	SCA9000A600V	Designed & Assembled In Canada By: www.surgicallycleanair.com	
2	Rating	600 V, 3 Ph, 60 Hz, 5.4 A 5 kA SCCR		
3	Fan Motor HP/kW	4.69 HP / 3.4 kW		
4	Serial Number			
			Sound Level <70 dBA	6

ATOMIK^{AIR}
POWERED BY SURGICALLY CLEAN AIR

1A-6300 Viscount Road, Mississauga, ON, L4V 1H3 Phone: 1-877-440-7770

QAI LABORATORIES
QAI-1000
www.qai.org

- 1 Model Number
- 2 System Technical Ratings Data
- 3 Fan Motor Power Rating
- 4 Serial Number
- 5 Product Name
- 6 Max Sound Level
- 7 Field Certification (* Labels will vary based on certifying organizations)
- 8 Manufacturer Contact Details

SPECIFICATIONS

NOMINAL DIMENSIONS

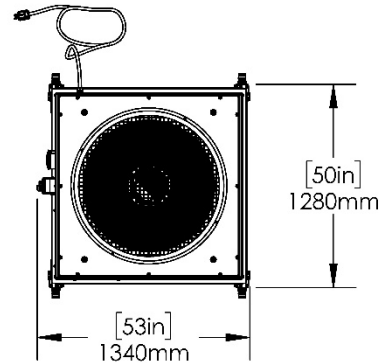

TOP VIEW

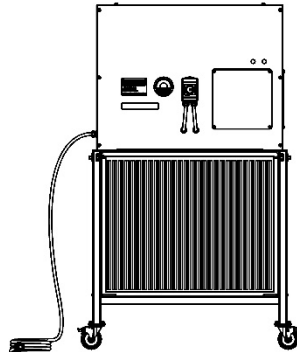

SIDE VIEW

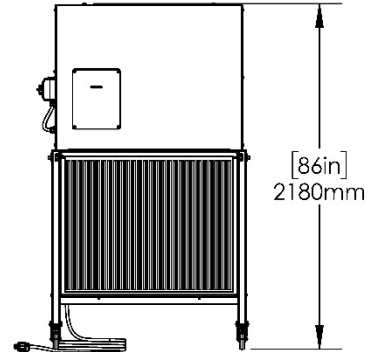

FRONT VIEW

PART IDENTIFICATION

COMPONENTS OVERVIEW

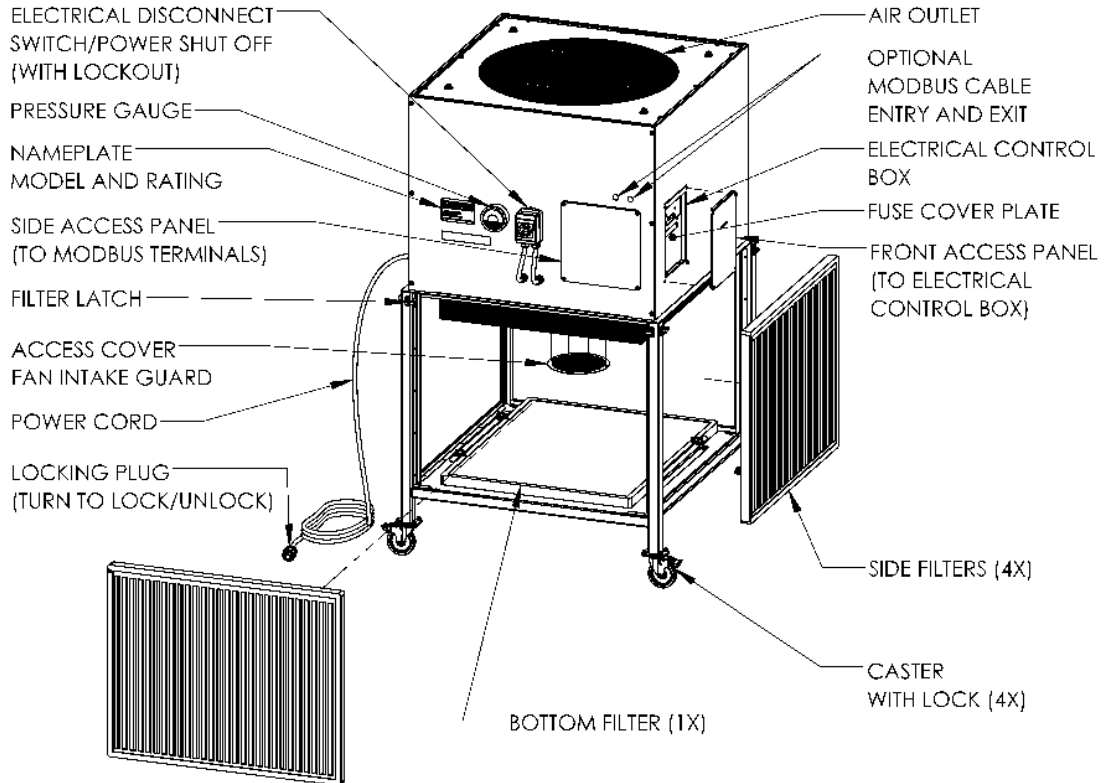

INSTALLATION



READ THROUGH THIS MANUAL IN ITS ENTIRETY BEFORE INSTALLING AND OPERATING THE EQUIPMENT.

SYSTEM PLACEMENT

- Observe all safety precautions as detailed in the Safety Precautions section of this manual.
- Ideal operating condition is between -20°C and +40°C ambient temperature.
- For best performance, position equipment in a central open area of the building.
- For spaces/ areas under 200,000 sq.ft, it's recommended to install a minimum of one system per 40,000 sq.ft for energy savings and destratification applications and one system per 20,000 sq. ft for high filtration applications.
- Equipment can be located adjacent to wall(s), with minimum 6" of clearance, 2 sides must be unobstructed.
- Ensure clear, unobstructed airflow into filters for optimum performance.
- For placement, to help mitigate specific facility issues during cold or warm outdoor weather climates:
 - For Cold Outdoor Climate Weather
 - If you are experiencing issues with "Cold Air Infiltration" through loading dock doors, you can locate the Atomik Air nearby loading docks and shipping areas where cold air ingress/drafts are present. The equipment will help to redistribute incoming cold air by propelling it towards the ceiling, this naturally causes the warm air to be pushed down and mix with the cooler incoming air – immediately raising the temperature at occupant level. This prevents the incoming cold air mass from travelling throughout your facility while simultaneously warming your shipping and receiving area workers and clearing the air of fumes and dust generated by trucks and forklifts.
 - For Warm Outdoor Climate Weather
 - Often during warm weather, facilities can experience stagnant air. For this application the Atomik Air system has an optional "Summer Hood" which redirects airflow horizontally. This provides a light, cooling breeze to the local area. If you did not purchase a summer hood, please reach out to your local dealer for details.

INSTALLATION

PRIOR TO COMMISSIONING

- Ensure to remove all packaging.
- Place unit on flat level surface and lock caster feet, ensure unit is stationary.
- Confirm fan alignment and bearing integrity by ensuring fan impeller rotates freely and does not rub, it should move smoothly and quietly. Refer to the Care and Maintenance section of this manual for impeller check instructions.

INSTALLATION

EQUIPMENT ELECTRICAL CONNECTIONS

Power supply connections to be made according to the table below:

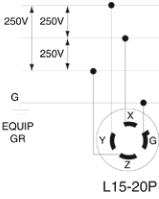
MODEL NUMBER	SCA9000C240V
POWER PLUG TYPE	Locking NEMA L15-20P
POWER PLUG WIRING SCHEMATIC	 <p>3~250 VAC, 20A</p>
POWER CORD	16 ft
NOMINAL VOLTAGE AND FREQUENCY	3~200-240 VAC, 50/60 Hz
SHORT CIRCUIT CURRENT RATING (SCCR)	Suitable for use on a circuit capable of delivering not more than 5000 rms symmetrical amperes, 480 volts maximum.
EQUIPMENT FUSE (X3)	6 Amp, 600 Volt, Class CC, time delay

INSTALLATION

EQUIPMENT MODBUS CONNECTIONS

- Modbus terminal strip connections are provided inside the unit and pre-wired to the fan. The terminal strip is accessible by unscrewing and removing the side access panel; inside the unit the terminal strip is mounted to the side of the electrical control box. Two cutouts in the exterior side panel above the access panel are supplied for customer cables and glands.
- Please reach out to SCA support and service to inquire for additional information regarding the unit MODBUS connection.

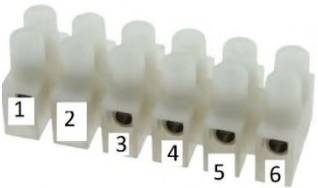
MODBUS CONNECTION SCHEME			
DIAGRAM	INTERNAL MODBUS TERMINAL	FUNCTION	DESCRIPTION
	1	A	RS-485 – RX+/TX+
	2	B	RS-485 – RX-/TX-
	3	GND	Digital Ground
	4	A	RS-485 – RX+/TX+ (connected to 1 via jumper)
	5	B	RS-485 – RX-/TX- (connected to 2 via jumper)
	6	GND	Digital Ground (connected to 3 via jumper)
Notes: Per RS-485 spec. users' Modbus cable should be a shield wrapped twisted pair.			

OPERATION

PRIOR TO INITIAL OPERATION



Prior to startup you must:

- Ensure all electrical connections and installation is properly completed.
- Ensure all guards, access panels, and covers are installed and securely fastened.
- Ensure all casters are in locked position.
- Ensure all filters are installed.

POWER ON/OFF

Turn the electrical disconnect switch, located on the side panel, to power the unit on and off while plugged in. When the equipment is powered on, a light is emitted behind the frosted pane of the front access panel of the electrical control box. equipment is intended for continuous duty operation, do not repeatedly switch on/off within a short period of time.



After turning on the unit, allow for 1 minute boot delay for the fan to start-up.

FILTERS

The unit has five washable/re-useable filters. All 5 filters (four sides and one bottom) must be installed to operate the unit. Operation without filters voids the warranty and can potentially damage fan and internal components.

PRESSURE GAUGE

A dial indicator pressure gauge is located on the side of the unit. The pressure reading is an indicator of the filter cleanliness. It is recommended to take note of the steady state pressure reading at the set operating speed with clean filters. As the filters become dirty the pressure reading will increase.



The pressure reading should be observed intermittently to determine when filter cleaning is required. When the pressure gauge indicator reads over the numbers indicated in table below it is time to clean the filters. Refer to the *Care and Maintenance* section filter cleaning instructions.

OPERATION

SUGGESTED FILTER CLEANING (SPEED/PRESSURE) CHART					
SPEED LEVEL	20%	40%	60%	80%	100%
PRESSURE GAUGE (Inch-H ₂ O)	-	>0.35	>0.45	>0.55	>0.8

FAN SPEED

The internal fan can operate continuously at variable speed setpoints from 0-100% and has a controller located inside the electrical control box. Some setpoints and their corresponding airflows are provided in the table below.

It is recommended to adjust fan speed occasionally if needed. It is common to adjust the setting seasonally in coordination with your heating and cooling ventilation changes.

Refer to the *Care and Maintenance* section for accessing and adjusting the speed settings.

FAN SPEED SETTINGS					
SPEED LEVEL	20%	40%	60%	80%	100%
APPROXIMATE AIRFLOW (CFM)	2800	5000	7500	9500	11000

Note: Actual airflow will vary based on filter cleanliness and environmental conditions.

CARE AND MAINTENANCE

PRIOR TO ANY MAINTENANCE OR SERVICING



Before performing any maintenance, service, or opening of panels, all safety measures and precautions within this manual must be followed.



WARNING – TO REDUCE THE RISK OF FIRE, ELECTRIC SHOCK, OR INJURY TO PERSONS, OBSERVE THE FOLLOWING:

- Always follow local and facility regulations for safe handling, maintenance, and disposal practices.
- Switch off the electrical disconnect switch and unplug the unit.
- Terminals and connections can remain live after disconnecting, wait 5-10 seconds prior to opening or accessing device.
- Ensure fan has stopped rotating and come to full stop.
- Motor housing and electronics can become hot during operation, proceed with caution.
- Ensure casters are locked and equipment is on a level surface
- Always use appropriate personal protective equipment (PPE) and do not wear loose or dangling clothing, or jewelry.

FILTERS

Refer to the *Operation* section of this manual for the pressure gauge readings that indicate when cleaning is required.

Follow your local regulations and protocols for filter cleaning intervals and dust collection related to specific contaminants and pollutants.

Over-cleaning your filters is not recommended. Filters become MORE efficient over time as dust and dirt collect on the filter, the airway path between the fibers narrows, resulting in higher efficiency in dust and dirt collection.

CARE AND MAINTENANCE

REGULAR CLEANING OF YOUR WASHABLE/RE-USEABLE FILTERS:

1. Remove all 5 filters, take note of the front outer facing (dirty) side of each filter as you remove it from the equipment. Turn the latches on the sides of the unit to release the filter and lift out. Similarly turn the latches on the bottom filter then lift and slide out.
2. Bring filters outside to an open area or to a safe handling location to collect debris.
3. Use compressed air on the backside (side facing inside equipment when installed) to blow off particulate and build up on the filter. A face mask is recommended to prevent inhalation of debris.
4. Place filters back in your system in the same orientation (front side facing out) until your next scheduled cleaning. Insert bottom filter first and turn latches to secure, then insert side filters and turn side latches to secure.

For occasional deep cleaning of your filters a pressure washer may be used. This is only recommended two to four times per year.

Be aware of the airflow direction sticker to ensure you cleaned them correctly and replaced them with the correct side facing out.



IMPORTANT: Always place the same side of the filter facing out after cleaning.

FAN

Fan bearings should be checked at least semi-annually to ensure they are quiet, can move easily and are free of play, perform impeller check as indicated below. Buildup of dust and debris on the impeller can cause imbalance in the fan and should be regularly visually inspected and cleaned when needed.

FAN IMPELLER CHECK and CLEANING

1. Remove side and bottom filters.
2. Unscrew the access cover located on the underside of the fan intake guard.

CARE AND MAINTENANCE

3. Perform a visual check to evaluate the impeller condition for signs of corrosion, abrasion, damage or dust and debris buildup.
 - a. If dust and debris buildup is prominent the fan impeller should be cleaned.
 - Never use high pressure cleaning equipment or steam cleaners
 - Do not use acid, lye, or solvent based cleaners.
 - Avoid any sharp or pointed objects for cleaning.
4. Using caution, avoid sharp edges, manually rotate the fan impeller, confirm smooth rotation, no rubbing or excessive noise.
 - a. If the fan does not rotate freely or noise, stiffness, or bearing play is observed contact your Authorized Distributer. Do not operate equipment.
 - b. If impeller smoothly rotates, reattach the access cover and securely fasten.

During long periods of shut down or while equipment is not in use it is recommended to run the unit for at least 1 hour per month, especially in humid environments.

The incorporated ball bearings are designed for a lifetime of 20,000 h to 40,000 h and maintenance free under ordinary operating conditions. For preventive maintenance ball bearings shall be changed after 5 years of service for grease aging. For ball bearing change contact your Authorized Distributer.

ELECTRICAL CONTROL BOX (Fan Speed Controller and Fuse Replacement)

The electrical control box, located behind the front access panel, contains the fan speed controller and the equipment fuses.

1. Unscrew and remove the access panel on front side of equipment.
 - a. **ADJUST FAN SPEED SETTING**
 - i. After the front access panel is removed, the fan speed controller lever is accessible in upper region of the electrical control box.



CARE AND MAINTENANCE

- ii. Slide the lever left or right to the desired fan speed setting. Refer to the *operation* section for fan speed and airflow values.
- b. REPLACE FUSES
- i. The fuse holder is located inside the lower compartment of the electrical control box.
 - ii. After the front access panel is removed, a secondary fuse cover plate must be unscrewed and removed to expose the fuse holder.
 - iii. Open the fuse holder by pulling down on the top front ledge.
 - iv. Carefully remove 3 fuses, sliding one at a time, up and out of the fuse holder. Note the fuse orientation while removing.
 - v. Dispose of used fuses according to local waste regulations.
 - vi. Risk of fire. Replace fuse only with new 6 Amp, 600 Volt, Class CC, time delay fuses.
 - vii. Insert, one at a time, each of the 3 new fuses in the same orientation as before. Always replace all 3 fuses together, do not mix old and new fuses.
 - viii. Close the fuse holder by pushing up and in.
 - ix. Reattach the fuse cover plate and securely fasten.
2. When adjustments are complete reattach the front access panel and securely fasten.

MAIN UNIT

The exterior painted metal surfaces of the equipment may be cleaned with an all-purpose or heavy-duty cleaner and degreaser. Apply cleaners to soft cloth or rag and wipe down exterior sides of unit. Do not spray or pour liquids on, or pressure wash the equipment structure/enclosure.

PRESSURE GAUGE

No periodic servicing is required. Keep case exterior and cover clean. Do not attempt to re-calibrate or field repair, as this will void the warranty.

CARE AND MAINTENANCE

A pressure line is factory installed within the frame to provide accurate pressure readings. Care should be taken during maintenance and servicing to avoid moving, damaging, or clogging the line.

MODBUS CONNECTIONS

1. Unscrew and remove the side access panel adjacent to the electrical disconnect switch
2. The Modbus terminal strip connections are located inside the unit on the side of the electrical box
3. When adjustments are complete reattach the access panel and securely fasten.

STORAGE

1. Store the unit in a dry place and protected from weather elements.
2. Please adhere to Storage temperatures between -30° C and 80° C.

TROUBLESHOOTING

Follow all safety precautions in this manual and the *Prior To Any Maintenance and Servicing* instructions in the Care and Maintenance section of before performing any actions.

ISSUE	POSSIBLE CAUSE	ACTION
Pressure gauge indicator is over 1 in H ₂ O or pressure gauge does not indicate or is sluggish	Dirty filters	Clean filters, refer to <i>Care and Maintenance</i> section.
	Pressure line tubing is blocked, pinched, or leaking	Remove filters and visually inspect the lower section of the pressure line to determine if tubing is blocked, pinched, or leaking. Remove the side access panel and check that the tubing connection to the fitting at the rear of the pressure gauge is tight and that there are no visible obstructions in the upper section of the tubing. If the line can easily be cleared or unobstructed perform minor adjustment only. If blockage is significant or tubing is damaged contact your Authorized Distributer.
Excessive noise and vibration	Fan speed setting is too high	Your equipment contains a high-power axial fan, some noise and mild vibration is normal for high-speed settings. Change the fan speed setting to a lower value for quieter operation, refer to the <i>Care and Maintenance</i> section instructions. If noise and vibration is in excess from typical operation continue to next line.
	Impeller is chafing	Perform fan impeller check and check for dirt or debris buildup on fan, clean if buildup is present, refer to the <i>Care and Maintenance</i> section instructions. If impeller does not rotate smoothly after cleaning contact your Authorized Distributer.
	Damaged or deformed fan bearings or impeller	Immediately stop unit and contact your Authorized Distributer.

TROUBLESHOOTING

Fan stops rotating while powered on	Fan electrical fault	Power off the unit for at least 2 minutes and restart. If operation does not return to normal contact your Authorized Distributer.
	Fan overheated	Power off the unit for at least 2 minutes. Inspect filters and clean if thick visible layer of buildup is present. Restart unit. Once restarted check the pressure gauge on the side of the unit, if reading is above 1" H ₂ O and filters are clean contact your Authorized Distributer.
	Fan jammed or blocked	Immediately stop unit and contact your Authorized Distributer.
Unit will not power on (i.e., no light emitted from electrical control box access panel window)	Fan Initial boot time	Wait for fan start-up. EC-motors require up to 1-minute boot delay after being energized.
	Power cord is loose or not plugged in correctly	Inspect the power cord and ensure plug is securely connected to outlet, turn to lock the plug.
	Electrical disconnect switch is OFF	Ensure the electrical disconnect switch is set to the ON position.
	Fuse is blown	Replace the fuses, refer to the <i>Care and Maintenance</i> section.
	Customer power supply issue	Contact qualified personnel to review your electrical system supply and installation.



SURGICALLY CLEAN AIR™

1A - 6300 Viscount Road
Mississauga, Ontario
Canada, L4V 1H3
Tel: 1-877-440-7770
www.surgicallycleanair.com
info@surgicallycleanair.com